

E1E11S\*\*E\*

E1E12S\*\*E\*

E1E13S\*\*E\*

SILICONE RUBBER / SPECIAL ELECTRONICS /  
LOW LOADS



Natural frequency : (1)  
20 to 25 Hz

## DESCRIPTION

- VHDS elastomer able to carry loads under compression and traction.
- Pedestal, washer and shaft in 18/8 stainless steel.

## APPLICATIONS

- Protecting electronic equipment, navigation equipment, instrument panels, measuring instruments, control panels on aircraft, road vehicles and railway trains.

## CHARACTERISTICS

Natural frequency :

- axial : 20 to 25 Hz;
- radial : 20 to 25 Hz.

Maximum permitted excitation at natural frequency of suspension :  $\pm 0.5$  mm.

Amplification factor at resonance < 5.

Operating temperature : - 54°C to + 150°C.

Structural strength corresponds to a continuous acceleration of 10 g at maximum load.

Maximum axial travel available for shock :

E1E11 : + 4mm / E1E12 : + 5 mm / E1E13 : + 7 mm.

Weight : E1E1 : 60 g / E1E12 : 120 g / E1E13 : 225 g.

These mounts meet the standard AIR7304 curve ZF

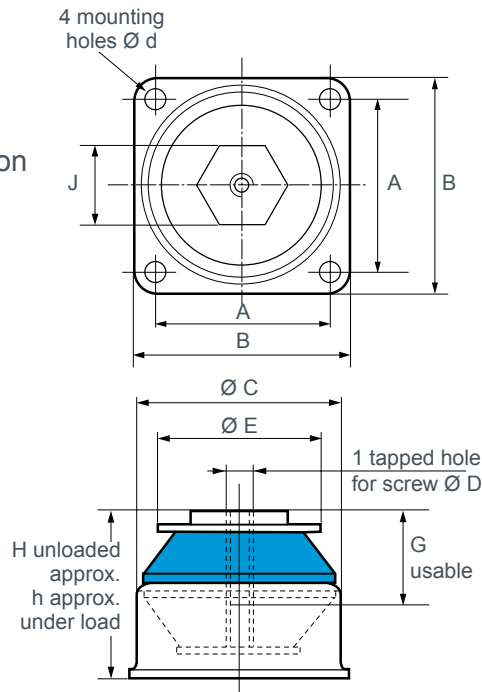

Reference	Range of use (daN)
E1E11S38EC	1,60 - 2,80
E1E11S42EC	1,80 - 3,20
E1E11S48EC	2,10 - 3,80
E1E11S55EC	2,50 - 4,50
E1E11S63EC	3,00 - 5,30
E1E11S72EC	3,50 - 6,20
E1E12S38ED	3,70 - 5,70
E1E12S42ED	4,00 - 6,30
E1E12S48ED	4,60 - 7,10
E1E12S55ED	5,20 - 8,10
E1E12S63ED	6,00 - 9,30
E1E12S72ED	6,60 - 10,30
E1E13S38EE	5,50 - 8,50
E1E13S42EE	6,00 - 9,50
E1E13S48EE	6,50 - 10,50
E1E13S55EE	7,50 - 12,00
E1E13S63EE	8,50 - 14,00
E1E13S72EE	10,00 - 16,00

Reference	A (mm)	B (mm)	Ø C (mm)	D	Ø E (mm)	H (mm)	J (mm)	Ø d (mm)	h (mm)	G (mm)
E1E11S□□EC	25,4	34	28,5	M5	23	29	14	4,3	28	10
E1E12S□□ED	34,9	44,4	40	M6	34,6	35,6	19	4,3	34,5	12
E1E13S□□EE	49,2	60,5	57	M8	45	47	23	5,3	45,5	16

1) the indicated natural frequency, are valid for the maxi loads of the ranges of use quoted in the paragraph : TECHNICAL CHARACTERISTICS.